

SELECTABLE CANDELA CEILING STROBE AND HORN/STROBE

I. INTRODUCTION

The Hochiki America Model HCS24 and HCC24, strobe and horn/strobe, are a high quality visible or audible/visible signaling appliance intended for ceiling applications. The high intensity strobe utilizes a Xenon flash tube that generates a high-intensity flash visible from all angles. This appliance is intended to provide a visible or audible/visible, depending on the model, notification signal for the purpose of life safety and property protection. This appliance is ideal for any occupancy that requires notification appliances per the applicable building or fire code or wherever dependable alarms are required. The HCS24 and HCC24 strobe is listed in compliance with ANSI/UL 1971, Signaling Appliances for the Hearing Impaired.

II. LOCATION

This appliance is intended for use in Fire Alarm Systems and is to be installed in accordance with this manual, the recommendation of the local authorities having jurisdiction, and other NFPA documents that provide standards on notification appliances for protective signaling systems. The HCS24 and HCC24 are intended for indoor installations only. This appliance is **not** listed for outdoor or drip proof applications. Spacing for the HCS24 and HCC24 shall be in accordance with TABLE A. If a room configuration is not square, the room size that will entirely encompass the room or subdivide the room into multiple squares shall be used.

III. MOUNTING, ROUGH-IN BOX AND RUN WIRING

This unit is designed for mounting to most single gang boxes, 4" square outlet boxes, 2-gang masonry boxes or non-metallic 2-gang switch boxes. Conduit entrance to boxes should be selected to insure sufficient wiring clearance.

1. Run a minimum 18 gauge insulated 2 or more conductor cable.
2. Mount a box for each remote signaling appliance. Screw bracket onto box. Insert signal into bracket and slide to the right firmly into the terminal block receptacle. Insert mounting screw as shown and tighten. Cover assembly with the plastic housing.

NOTICE: WIRING SHOULD BE CONNECTED TO MOUNTING BRACKET PRIOR TO MOUNTING SIGNAL. INCOMING POSITIVE POWER LEAD MUST BE BROKEN AND EACH LEAD IS TO BE INSERTED INTO EACH OF THE TOP TWO TERMINALS. IF TWO POWER RUNS ARE MADE TO THE SIGNAL, ONE FOR THE STROBE AND ONE FOR THE HORN, ONLY ONE OF THE RUNS MUST HAVE ITS POSITIVE LEAD BROKEN AND PLACED UNDER THE TWO SEPARATE TOP TERMINALS. A BARRIER IS PROVIDED TO PREVENT BOTH LEADS FROM BEING PLACED UNDER THE SAME TERMINAL.

TABLE A

| Room Spacing for Ceiling-Mounted Visible Appliances per NFPA 72, 2010 Edition | | | | |
|---|---------|--|-----------------|-----------------|
| Maximum Room Size | | Minimum Required Light Output (Effective Intensity, Cd; One Light) | | |
| | | Maximum Ceiling Height | | |
| Meters | Feet | 10 Foot Ceiling | 20 Foot Ceiling | 30 Foot Ceiling |
| 6.10 x 6.10 | 20 x 20 | 15 | 30 | 55 |
| 9.14 x 9.14 | 30 x 30 | 30 | 45 | 75 |
| 13.4 x 13.4 | 44 x 44 | 75 | 75 | NA |
| 15.2 x 15.2 | 50 x 50 | 95 | 95 | 95 |

LIGHT OUTPUT IN PERCENTAGE WHEN MEASURED FROM THE FOLLOWING DIRECTIONS - PER UL1971

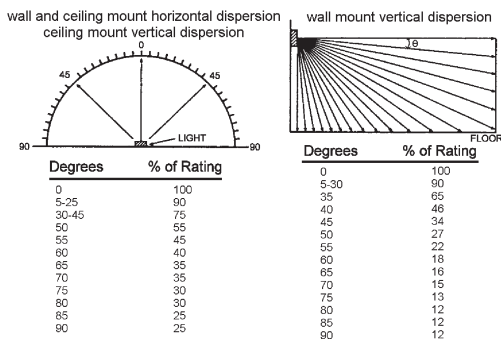

CAUTION: Strobe light must be installed within 16 feet of the pillow when used in a sleeping area.

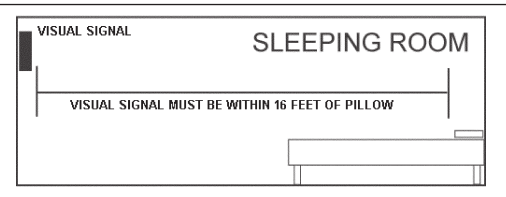

NOTICE: THE VISUAL SIGNAL MUST BE IN THE DIRECT VIEWING AREA OF THE OCCUPANT IN ORDER TO BE SEEN.

WARNING Strobe light can not be seen when objects such as doors, furniture or walls block strobe light.

NOTICE: VISUAL SIGNALS FOR THE HEARING IMPAIRED ARE ONLY ONE METHOD OF ALERTING THE HEARING IMPAIRED. VISUAL SIGNALS MAY NOT BE THE PREFERRED METHOD FOR NOTIFYING ALL HEARING IMPAIRED INDIVIDUALS.

NOTICE: THE STROBE LIGHT MUST BE SEEN BY THE SLEEPING PERSON. IF THE PERSON HAS HEAD TURNED OR OTHERWISE UNABLE TO BE ALERTED BY VISUAL, THE STROBE WILL NOT BE EFFECTIVE.

| CLEAR Lens Strobe Current Ratings | | |
|-----------------------------------|---|--|
| Use with HCS24 and HCC24 Products | | |
| Candela | Regulated 24VDC Max. Operating Current (mA) | Regulated 24VFWR Max. Operating Current (mA) |
| 15 | 120 | 190 |
| 30 | 120 | 191 |
| 75 | 200 | 277 |
| 95 | 220 | 298 |
| 115 | 290 | 418 |
| 150 | 321 | 427 |

NOTICE: DC VOLTAGE RANGE LIMITS: 16-33V. FWR VOLTAGE RANGE LIMITS: 16-33V. THIS PRODUCT WAS ONLY TESTED TO THE STATED VOLTAGE RANGE(S); DO NOT APPLY 80% AND 110% OF THIS RANGE FOR SYSTEM OPERATION.

HORN DECIBEL AND CURRENT RATINGS PRODUCT INFORMATION

| Horn Mode | Horn Decibel Levels | | Horn Current Ratings | |
|-----------------------|--|---|---|--|
| | Minimum SPL @ 10Ft. Per ANSI/UL 464 (HIGH) | Minimum SPL @ 10Ft. Per ANSI/UL 464 (LOW) | Regulated 24VDC Max. Operating Current (mA) High Setting | Regulated 24VFWR Max. Operating Current (mA) High Setting |
| Temp 3 2400Hz | 83 dBA | 75 dBA | 23 | 45 |
| Temp 3 Mechanical | 81 dBA | 73* dBA | 22 | 43 |
| Continuous 2400Hz | 86 dBA | 78 dBA | 23 | 45 |
| Continuous Mechanical | 84 dBA | 76 dBA | 22 | 43 |

NOTICE:

- ◆ THE THREE PULSE TEMPORAL PATTERN IS TO BE USED FOR EVACUATION USE ONLY.
- ◆ THE SOUND OUTPUT FOR THE TEMPORAL 3 TONE IS RATED LOWER SINCE THE TIME THE HORN IS OFF IS AVERAGED INTO THE SOUND OUTPUT RATING. WHILE THE HORN IS PRODUCING A TONE IN THE TEMPORAL 3 MODE ITS SOUND PRESSURE IS THE SAME AS THE CONTINUOUS MODE. UNITS HAVE BEEN TESTED TO 0°C, 49°C AND 93% HUMIDITY.

*Operating the horn in this mode at this voltage will result in not meeting the minimum ANSI/UL 464 sound level required for public mode fire protection service. These settings are acceptable only for private mode fire alarm signaling use. Use the high dBA setting for public mode applications.

IV. WIRING

Wiring for independent synchronized strobes and horn

Using this method you may:

- ◆ Use only two wires to synchronize the temporal horn and strobe with the ability to mute the horn (place switches 1 and 2 up on the HCC24).
- ◆ Mute the horn only when the temporal horn option has been selected.

Wiring for synchronized parallel (unison) horn/strobe operation

Using this method you may:

- ◆ Use only two wires to synchronize the temporal horn and strobe **without** the ability to mute the horn (place switches 1 and 2 up on the HCC24).
- ◆ Choose either temporal or continuous horn with the temporal horn synchronized.
- ◆ Also wire the control module (HAVSM) to only the strobe input power terminals, set the horn to continuous mode and power it from a coded source.

NOTICE: FOR THIS OPTION, SWITCHES 1 AND 2 ON THE HCC24 MUST BE DOWN TO ISOLATE POWER TO THE AUDIBLE AND VISIBLE PORTION OF THE CIRCUIT.

NOTICE: ALL STROBES ARE DESIGNED TO FLASH AS SPECIFIED WITH CONTINUOUS APPLIED VOLTAGE. THIS APPLIANCE IS NOT RECOMMENDED FOR USE ON CODED OR PULSING SIGNALING CIRCUITS. HOWEVER, USE OF THE HAVSM CONTROL MODULE IS PERMITTED TO SYNCHRONIZE THE STROBE AND/OR MUTE THE HORN.

NOTICE: REFERENCE HAVSM CONTROL MODULE MANUAL (550-0539, DATED 03/04/11) FOR SYNCHRONIZATION MODULE WIRING DIAGRAMS. HAVSM MANUAL CAN BE OBTAINED AT [HTTP://WWW.HOCHIKI.COM](http://www.hochiki.com) OR CALL HOCHIKI AMERICA CORPORATION AT 714-522-2246.

| $\text{MAX. WIRE DISTANCE (IN FEET)} = \left(\frac{\text{(PANEL VOLTAGE - APPLIANCE MIN. VOLT)} \times \text{WIRE CONDUCTIVITY}}{\text{TOTAL CURRENT DRAW}} \right)$ | | | | | | | | | | |
|--|--------------|--------------|-------|----|-------|----|-------|-----|-------|-----|
| <table border="1"> <thead> <tr> <th>WIRE</th> <th>CONDUCTIVITY</th> </tr> </thead> <tbody> <tr> <td>18AWG</td> <td>60</td> </tr> <tr> <td>16AWG</td> <td>95</td> </tr> <tr> <td>14AWG</td> <td>153</td> </tr> <tr> <td>12AWG</td> <td>244</td> </tr> </tbody> </table> | WIRE | CONDUCTIVITY | 18AWG | 60 | 16AWG | 95 | 14AWG | 153 | 12AWG | 244 |
| WIRE | CONDUCTIVITY | | | | | | | | | |
| 18AWG | 60 | | | | | | | | | |
| 16AWG | 95 | | | | | | | | | |
| 14AWG | 153 | | | | | | | | | |
| 12AWG | 244 | | | | | | | | | |
| <p>Includes wire to and from appliance. CAUTION: Applies only to regulated supplies. Assumes all appliances are at the end of wire run (worst case).</p> | | | | | | | | | | |

Conventional Method:

You may connect both the strobe and the horn directly from a source of rated power without the use of a control module. However, the horns and strobe lights will NOT be synchronized. Place switches 1 and 2 up on the HCC24 to power both the audible and visible from a single pair of power wires. If you wish to power the horn and strobe from independent sources of power, place switches 1 and 2 down on the HCC24 and connect power to the appropriate terminals.

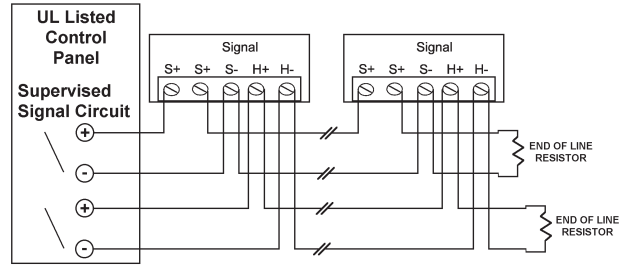
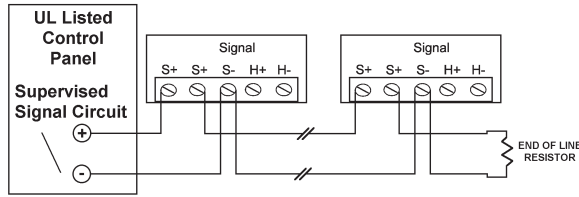

CAUTION: When using only a single power source to energize the strobe and horn (switches 1 and 2 up), the in/out wiring must be under the S+ and S- terminals only. Failure to do so may result in damage to your signal.

Adjust candela by turning dial. Displayed number will be candela selected.

NOTICE: TO PREVENT ACCIDENTAL CANDELA SELECTION CHANGE, REMOVE THE SCREW FROM THE UNLOCK POSITION AND PLACE IN THE LOCK POSITION AFTER THE DESIRED INTENSITY IS SELECTED.

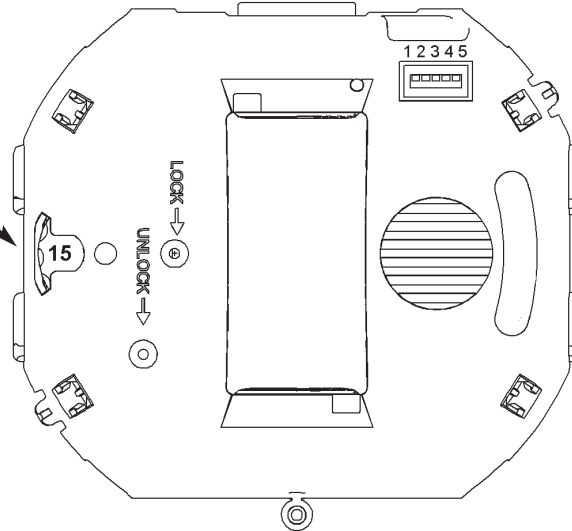

Switch positions 1 and 2 in the down position to select isolated horn and strobe power inputs.

Switch 3 selects between temporal or non-temporal tone. Up is temporal.

Switch 4 selects between mechanical or high frequency tone. Up is mechanical.

Switch 5 selects between high or low dBA. Up is high dBA.

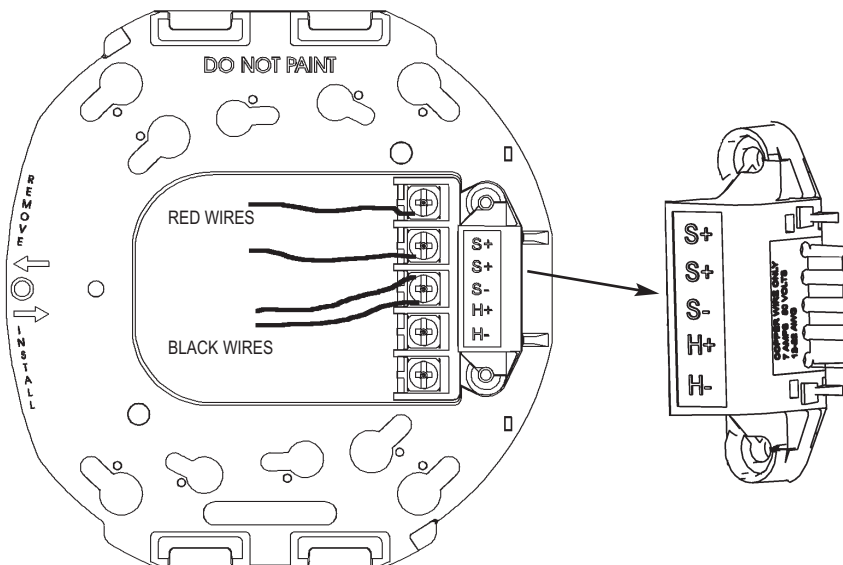

The mounting bracket allows the installer to pre-wire the system, test for system supervision, remove the signal head until occupancy, switch out signals without changing mounting brackets and has locking edge connector for snap-in-place installation.

Instant Voltage Verification

It is often necessary to confirm the voltage drop along a line of devices. The access holes are provided in the back of the terminal block to allow the voltage to be measured directly without removing the device. Typically this would be done at the end of the line to confirm design criteria. Most measurements will be taken using the S+ and S- locations although access is provided to other locations.

NOTICE: CARE SHOULD BE TAKEN TO NOT SHORT THE TEST PROBES.

CAUTION: A jumper card is provided to test for correct wiring in the supervisory mode only. DO NOT pass alarm current through the jumper.

3. SNAP COVER OVER ASSEMBLY
2. INSERT MOUNTING SCREW

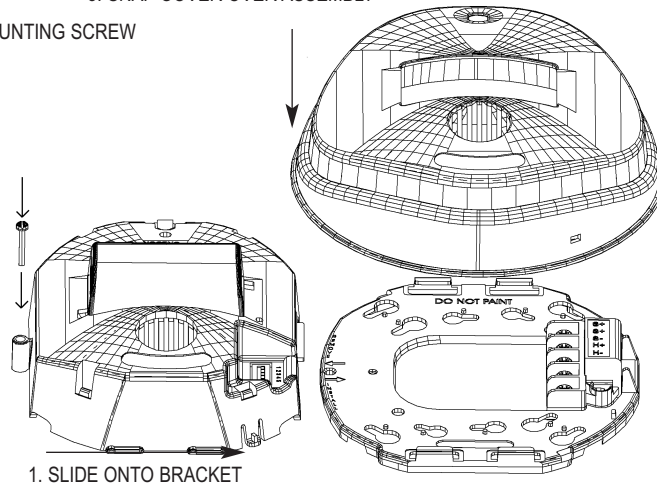

V. CHECKOUT AND TROUBLESHOOTING

1. Supply power to the system control panel. The auxiliary signaling appliances in the system should not be activated.
2. If the signal is activated:
 - ♦ Check all smoke and fire detectors in the system to make sure they have not been activated.
 - ♦ Check all wiring connections to make sure the signal detection circuits are not reversed or shorted together. Check wire color codes and traces.
 - ♦ Verify that the jumpers and switches are properly set on both the control module and signal appliance. If the jumper on the HAVSM is removed, the horns will not produce any sound unless there is an input to the H+ and H- terminals on the control module.
3. To test the signal appliances, trip the auxiliary panel or activate the alarm circuit at the main control panel or activate one of the fire detection units in the system. All auxiliary signals should be activated.
4. An operational test on this product should be conducted in accordance with National Standards or at a minimum annually and more often if dictated by local and state codes or authorities having jurisdiction.

NOTICE: THESE TESTING PROCEDURES AND TROUBLESHOOTING INSTRUCTIONS ARE GENERALIZED. PLEASE REFER TO THE SYSTEM CONTROL PANEL OPERATING INSTRUCTIONS FOR PROPER OPERATION OF THE PANEL AND FIRE DETECTION SYSTEM.

SIGNALING APPLIANCE LIMITATION:

Your horn and horn/strobe meet or exceed the current audibility requirements of ANSI/UL 464. However, if the appliance is located outside a bedroom it may not wake up a sound sleeper, especially if the room door is closed or only partially open.

▲ WARNING

THIS APPLIANCE WILL NOT OPERATE WITHOUT ELECTRICAL POWER. AS FIRES FREQUENTLY CAUSE POWER INTERRUPTIONS, HOCHIKI AMERICA SUGGESTS YOU DISCUSS FURTHER SAFEGUARDS WITH YOUR LOCAL FIRE PROTECTION SPECIALIST.

VI. TO RETURN AN APPLIANCE

Should you experience problems with your appliance, proceed as follows:

1. Turn off electrical power to the auxiliary alarm circuit.
2. Remove faceplate, then remove mounting screw and slide signal off from bracket.
3. Replace unit that was removed to restore wiring supervision and to eliminate system trouble alert.
4. Carefully pack the defective unit (the manufacturer cannot be responsible for consequential damage due to shipping or mis-handling). Include your return address and complete details as to the nature of the difficulties being experienced and date of installation.
5. Return to: Hochiki America Corporation, 7051 Village Drive, Suite 100, Buena Park CA 90621. Prior to returning, call the Hochiki America field service department at 714-522-2246.

LIMITED WARRANTY

For a period of 36 months from the date of purchase or a maximum of 42 months from the date of manufacture, Hochiki America warrants to you the original purchaser that your appliance will be free from defects in workmanship, materials and construction under normal use and service. If a defect in workmanship, materials and construction should cause your appliance to become inoperative within the warranty period, Hochiki America will repair your appliance or furnish you with a new or rebuilt appliance without charge to you except for postage required to return the appliance to us. Hochiki America will not reimburse you for repairs or replacement parts provided by other parties. Your repaired or replacement appliance will be returned to you free of charge and it will be covered under the warranty for the balance of the warranty period.

The warranty is void if our inspection of your appliance shows that the damage or failure was caused by abuse, misuse, abnormal usage, faulty installation, improper maintenance or repairs other than those performed by us.

ANY WARRANTIES IMPLIED UNDER ANY STATE LAW INCLUDING IMPLIED WARRANTIES OF MERCHANTABILITY OR FITNESS FOR A PARTICULAR PURPOSE APPLY ONLY FOR THE WARRANTY PERIOD SPECIFIED ABOVE. PLEASE NOTE THAT SOME STATES DO NOT ALLOW LIMITATION ON HOW LONG AN IMPLIED WARRANTY LASTS. SO THE ABOVE LIMITATION MAY NOT APPLY TO YOU. HOCHIKI AMERICA WILL NOT BE LIABLE FOR ANY LOSS, DAMAGE, INCIDENTAL OR CONSEQUENTIAL DAMAGES OF ANY KIND ARISING IN CONNECTION WITH THE SALE, USE OR REPAIR OF THIS APPLIANCE. THE MAXIMUM LIABILITY OF HOCHIKI AMERICA SHALL NOT IN ANY CASE EXCEED THE PURCHASE PRICE PAID BY YOU FOR THE APPLIANCE. PLEASE NOTE THAT SOME STATES DO NOT ALLOW THE EXCLUSION OR LIMITATION OF INCIDENTAL OR CONSEQUENTIAL DAMAGES, SO THE ABOVE LIMITATION OR EXCLUSION MAY NOT APPLY TO YOU.

If a defect in workmanship, materials or construction should cause your appliance to become inoperative within the warranty period, you must return the appliance to Hochiki America postage prepaid. You must prove to the satisfaction of Hochiki America the date of purchase of your appliance. Warranty service may only be performed by Hochiki America personnel at Hochiki America's facilities in Buena Park, California. You must also pack the appliance to minimize the risk of it being damaged in transit. You must also enclose a return address. Appliances returned for warranty service should be sent to: Hochiki America Corporation, 7051 Village Drive, Suite 100, Buena Park CA 90621. If we receive an appliance in a damaged condition as the result of shipping, we will notify you and you must seek a claim with the shipper.

THIS WARRANTY GIVES YOU SPECIFIC LEGAL RIGHTS AND YOU MAY ALSO HAVE OTHER RIGHTS WHICH VARY FROM STATE TO STATE.

Important Notice:

These materials have been prepared by Hochiki America Corporation ("Hochiki America") for informational purposes only, are necessarily summary, and are not purposed to serve as legal advice and should not be used as such. Hochiki America makes no representations and warranties, express or implied, that these materials are complete and accurate, up-to-date, or in compliance with all relevant local, state and federal laws, regulations and rules. The materials do not address all legal considerations as there is inevitable uncertainty regarding interpretation of laws, regulations and rules and the application of such laws, regulations and rules to particular fact patterns. Each person's activities can differently affect the obligations that exist under applicable laws, regulations or rules. Therefore, these materials should be used only for informational purposes and should not be used as a substitute for seeking professional legal advice. Hochiki America will not be responsible for any action or failure to act in reliance upon the information contained in this material.

Hochiki America Corporation
7051 Village Drive, Suite 100
Buena Park, CA 90621 USA
Phone: 714-522-2246
www.hochiki.com